

Headstock-Tailstock Positioners

▶▶ HTS series

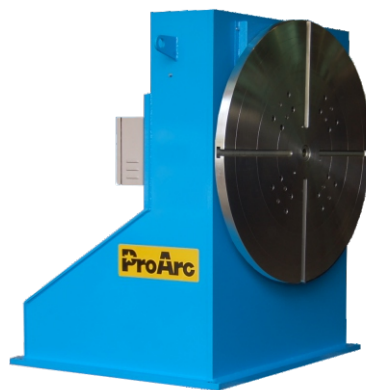

Features

- All welded steel frame structure.
- For long weldments rotation.
- Capacities range from 500 to 20,000 kilograms.
- Machined "T" slots table with pilot and through hole.
- A. C. inverter drive for rotation.
- Forward-Stop-Reverse and variable speed control are standard.
- Totally gear-safe design.
- Maintenance-free grounding system.
- Optional adjustable table height to fit larger workpiece.

Dimensions

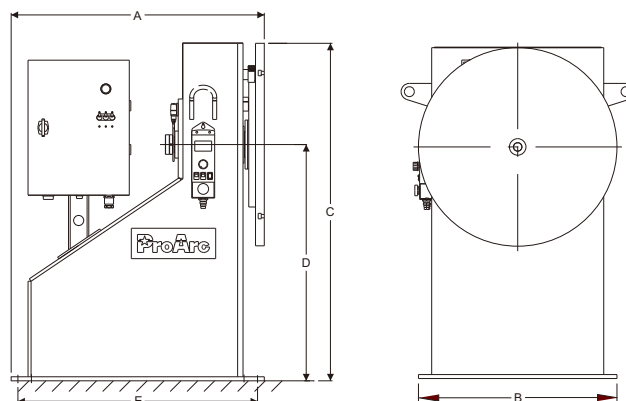

Specifications

Specification															
Model	Unit	HTS-600		HTS-1000		HTS-3000		HTS-6000		HTS-10K		HTS-15K		HTS-20K	
HS-Headstock / TS-Tailstock		HS-300	TS-300	HS-500	TS-500	HS-1,500	TS-1,500	HS-3,000	TS-3,000	HS-5,000	TS-5,000	HS-7,500	TS-7,500	HS-10K	TS-10K
Power input		AC 220V, 50 / 60Hz, 1 phase				AC 220 / 380V, 50 / 60Hz, 3 phase									
Rotation motor	hp	1/6		1/2		1		2		3		3		3	
Overall length (A)	mm	510		750		900		1,000		1,150		1,350		1,350	
Overall width (B)	mm	500		600		1,000		1,100		1,200		1,500		1,500	
Overall height (C)	mm	825		1,000		1,175		1,300		1,600		2,000		2,000	
Center to floor (D)	mm	600		700		800		800		1,000		1,250		1,250	
Bolt-down hole dia.*square (E)	mm	20*450		20*600		20*750		24*900		28*1,000		28*1,200		28*1,200	
Capacity	kg	300	300	500	500	1,500	1,500	3,000	3,000	5,000	5,000	7,500	7,500	10,000	10,000
Total loading capacity	kg	600		1,000		3,000		6,000		10,000		15,000		20,000	
Rated center of gravity	mm	100		300		300		300		300		300		300	
Eccentric load torque rating	kg-cm	3,000		15,000		45,000		90,000		150,000		225,000		300,000	
Table dimension	mm	450		600		750		1,000		1,200		1,500 x 1,500		1,500 x 1,500	
Table pilot hole (dia. x depth)	mm	25 thru hole		25 thru hole		100*6		100*6		100*6		125*6		125*6	
Table slot bolt size		M12		M12		M16		M16		M24		M30		M30	
Rotation speed	rpm	0.12 ~ 2.5		0.05 ~ 1		0.05 ~ 1		0.05 ~ 1		0.04 ~ 0.8		0.04 ~ 0.8		0.04 ~ 0.8	
Earthing	amp	600		600		600		600		600		600		600	

Specifications subject to change without notice

UNITED PROARC CORPORATION

No.3, Gungye 10th Road, Pingjen Ind. Park, Pingjen City, Taoyuan 32459, Taiwan
 Tel: 886-3-4696600 Fax: 886-3-4694499 <http://www.proarc.com.tw> E-mail:sales@proarc.com.tw